



60 minutes



CAIS

CONNECT 60 ASSEMBLY MANUAL

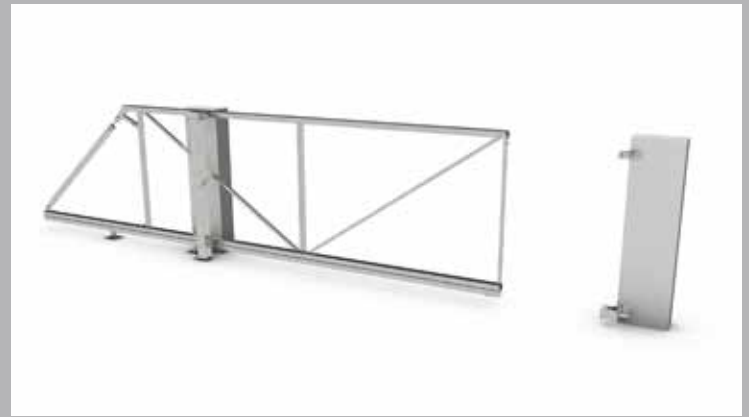

VIDEO
MANUAL



CONSTRUCTION
SITE PREPARATION

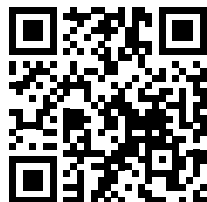

DIAGON 60
SETTING

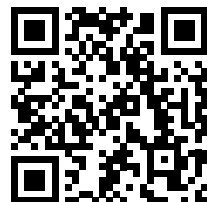

CAIS
CATALOG

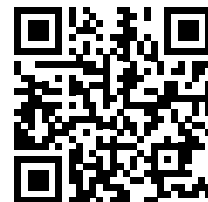











| CONNECT 60 - 4.0/1.1 | | |
|-----------------------|-------------------|-------|
| CODE | ART. | PCS |
| | FRAME 1.1 | 1 pc |
| | KIT - BOLTS, NUTS | 1 pc |
| 1700004 | RUN S | 1 pc |
| 1700005 | LAST S | 1 pc |
| 1700007 | PILOT SN | 1 pc |
| 1700404 | PILOT SR | 1 pc |
| 1700174 | SPEED SE | 2 pcs |
| 1700237 | DIAGON 60 | 1 pc |
| 1700339 | JRS 30 | 1 pc |
| 1700359 | PARK CSM | 1 pc |
| 1700367 | DOCKER O | 1 pc |
| 1720016 | STAGE SZ 2,8 | 2 pcs |
| Total weight = 135 kg | | |
| CODE: 1710800 | | |

| CONNECT 60 - 4.0/1.3 | | |
|-----------------------|-------------------|-------|
| CODE | ART. | PCS |
| | FRAME 1.3 | 1 pc |
| | KIT - BOLTS, NUTS | 1 pc |
| 1700004 | RUN S | 1 pc |
| 1700005 | LAST S | 1 pc |
| 1700007 | PILOT SN | 1 pc |
| 1700404 | PILOT SR | 1 pc |
| 1700174 | SPEED SE | 2 pcs |
| 1700237 | DIAGON 60 | 1 pc |
| 1700339 | JRS 30 | 1 pc |
| 1700359 | PARK CSM | 1 pc |
| 1700367 | DOCKER O | 1 pc |
| 1720016 | STAGE SZ 2,8 | 2 pcs |
| Total weight = 139 kg | | |
| CODE: 1710801 | | |

| CONNECT 60 - 4.0/1.5 | | |
|-----------------------|-------------------|-------|
| CODE | ART. | PCS |
| | FRAME 1.5 | 1 pc |
| | KIT - BOLTS, NUTS | 1 pc |
| 1700004 | RUN S | 1 pc |
| 1700005 | LAST S | 1 pc |
| 1700007 | PILOT SN | 1 pc |
| 1700404 | PILOT SR | 1 pc |
| 1700174 | SPEED SE | 2 pcs |
| 1700237 | DIAGON 60 | 1 pc |
| 1700339 | JRS 30 | 1 pc |
| 1700359 | PARK CSM | 1 pc |
| 1700367 | DOCKER O | 1 pc |
| 1720016 | STAGE SZ 2,8 | 2 pcs |
| Total weight = 142 kg | | |
| CODE: 1710802 | | |

| CONNECT 60 - 4.0/1.8 | | |
|-----------------------|-------------------|-------|
| CODE | ART. | PCS |
| | FRAME 1.8 | 1 pc |
| | KIT - BOLTS, NUTS | 1 pc |
| 1700004 | RUN S | 1 pc |
| 1700005 | LAST S | 1 pc |
| 1700007 | PILOT SN | 1 pc |
| 1700404 | PILOT SR | 1 pc |
| 1700174 | SPEED SE | 2 pcs |
| 1700237 | DIAGON 60 | 1 pc |
| 1700339 | JRS 30 | 1 pc |
| 1700359 | PARK CSM | 1 pc |
| 1700367 | DOCKER O | 1 pc |
| 1720016 | STAGE SZ 2,8 | 2 pcs |
| Total weight = 146 kg | | |
| CODE: 1710806 | | |

| RUN S | LAST S | PILOT SN | PILOT SR | SPEED SE | DIAGON 60 | JRS 30 | PARK CSM | DOCKER O | STAGE SZ 2,8 |
|--|---|---|---|---|---|--|---|---|---|
|  |  |  |  |  |  |  |  |  |  |
| 1700004 | 1700005 | 1700007 | 1700404 | 1700174 | 1700237 | 17339 | 1700367 | 1700367 | 1720016 |

| SECTION 1 | |
|-----------|--------|
| HEIGHT | WEIGHT |
| mm | kg |
| 1100 | 19 |
| 1300 | 20 |
| 1500 | 21 |
| 1800 | 22 |

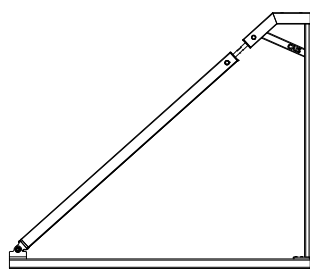

| SECTION 2 | |
|-----------|--------|
| HEIGHT | WEIGHT |
| mm | kg |
| 1100 | 25,5 |
| 1300 | 27 |
| 1500 | 28,5 |
| 1800 | 30 |

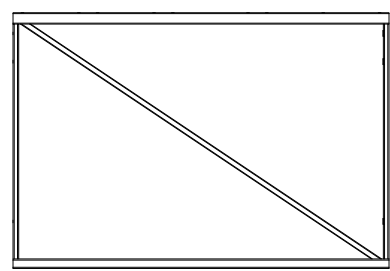

| SECTION 3 | |
|-----------|--------|
| HEIGHT | WEIGHT |
| mm | kg |
| 1100 | 25,5 |
| 1300 | 27 |
| 1500 | 28,5 |
| 1800 | 30 |

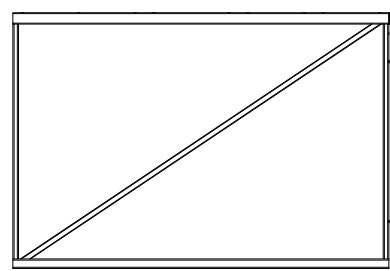

MAXIMUM LOAD ON THE GATE FRAME 125 kg

| TOWER 1.1 |
|----------------------|
| Total weight = 12 kg |
| CODE: 1710803 |
| Profile 100x100x3 |

| TOWER 1.3 |
|------------------------|
| Total weight = 13,5 kg |
| CODE: 1710804 |
| Profile 100x100x3 |

| TOWER 1.5 |
|----------------------|
| Total weight = 15 kg |
| CODE: 1710805 |
| Profile 100x100x3 |

| TOWER 1.8 |
|------------------------|
| Total weight = 17,5 kg |
| CODE: 1710807 |
| Profile 100x100x3 |

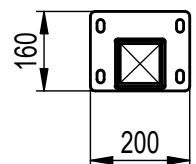
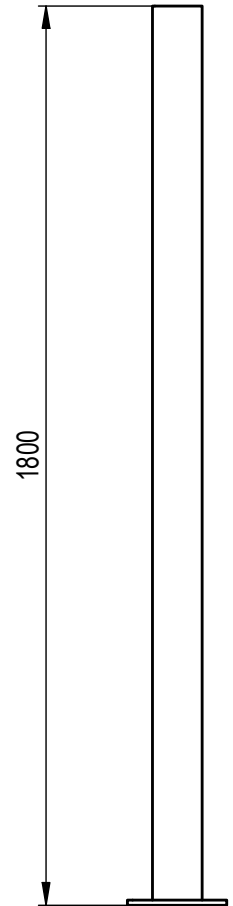
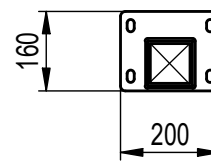
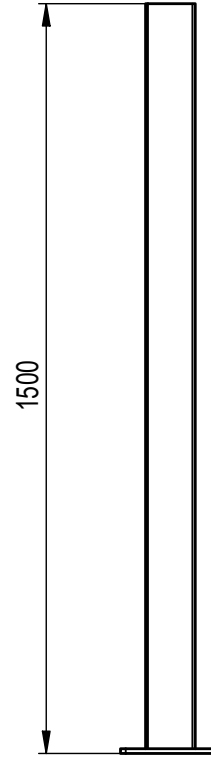
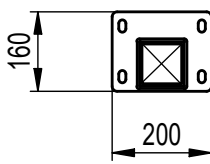
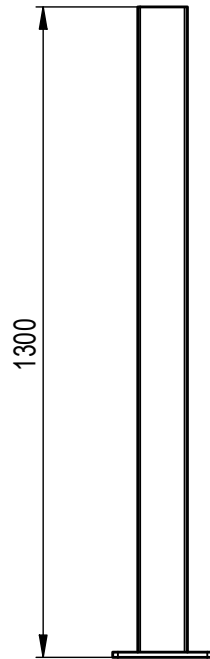
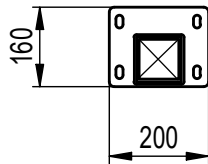
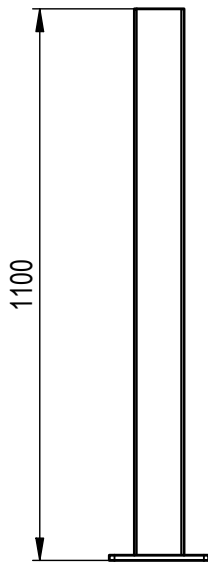

***NOT INCLUDED IN SET CONNECT 60**

DRIVEWAY 4000 mm

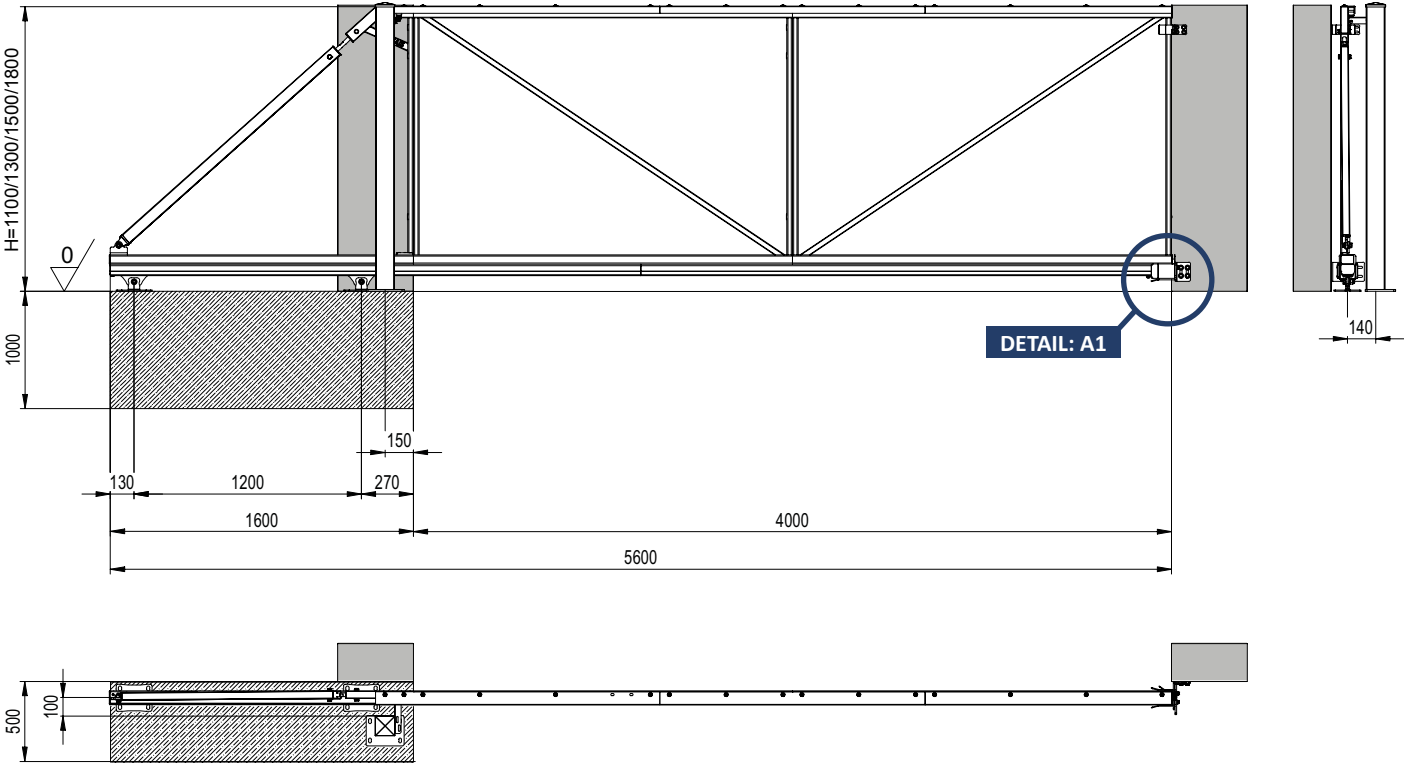

A1 (1:20)

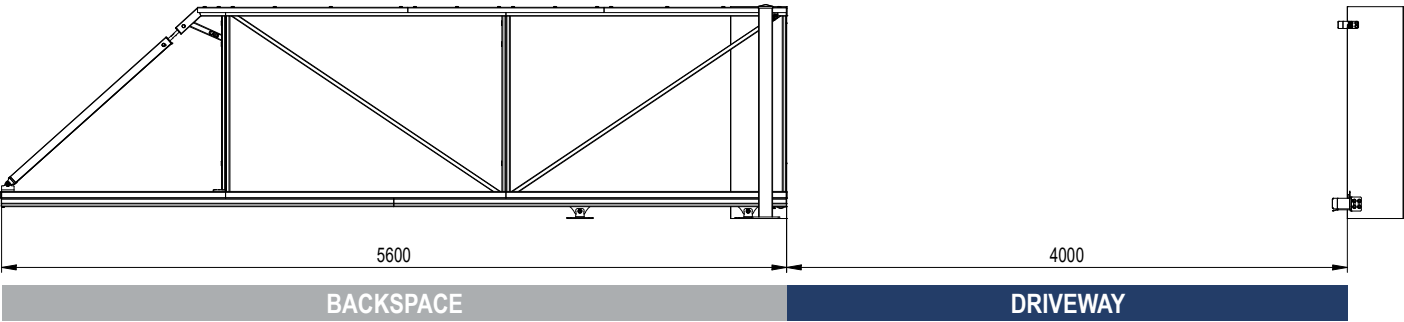
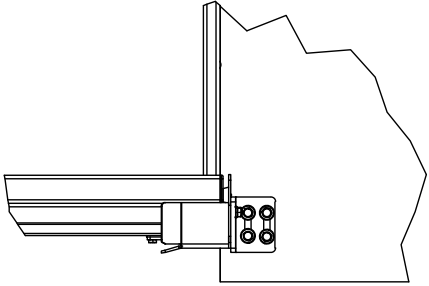

DRIVEWAY 3900 mm

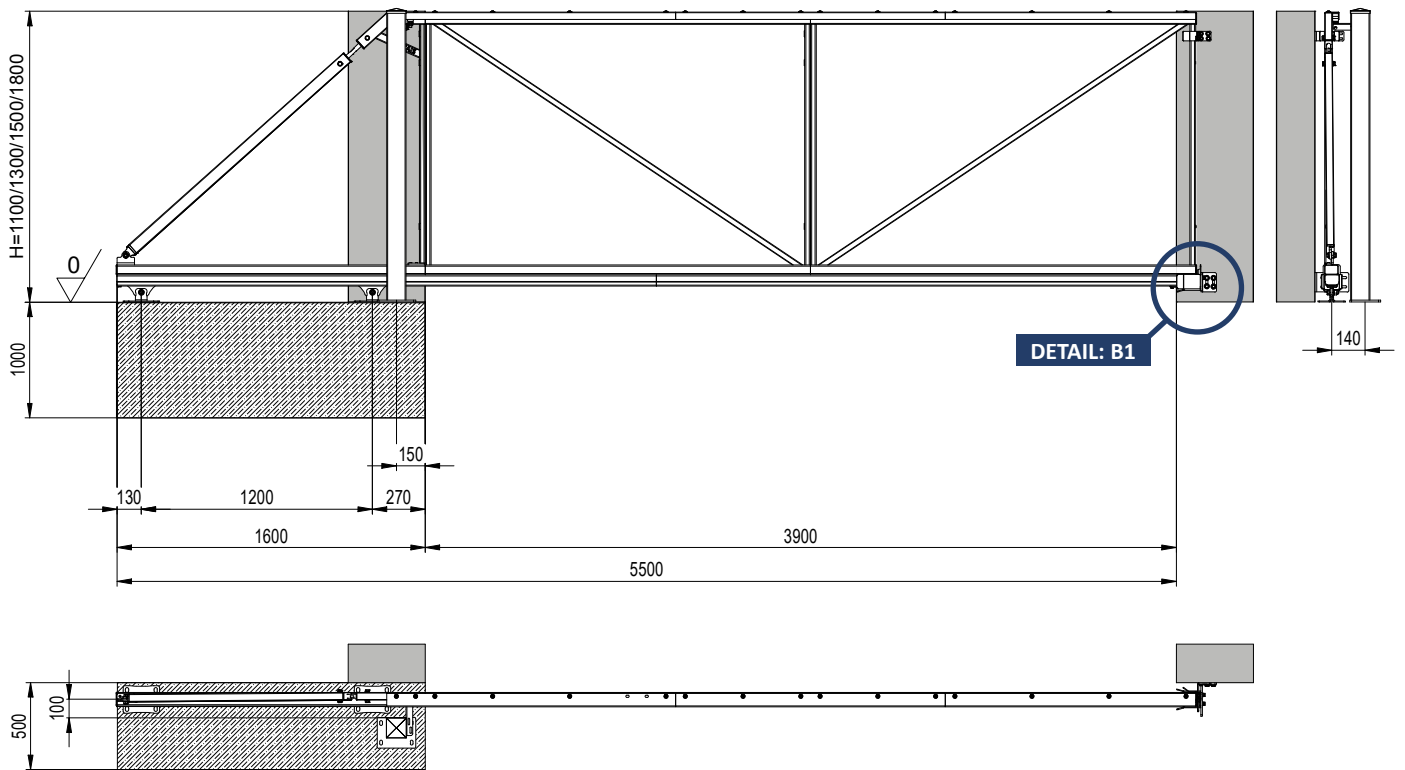

B1 (1:20)

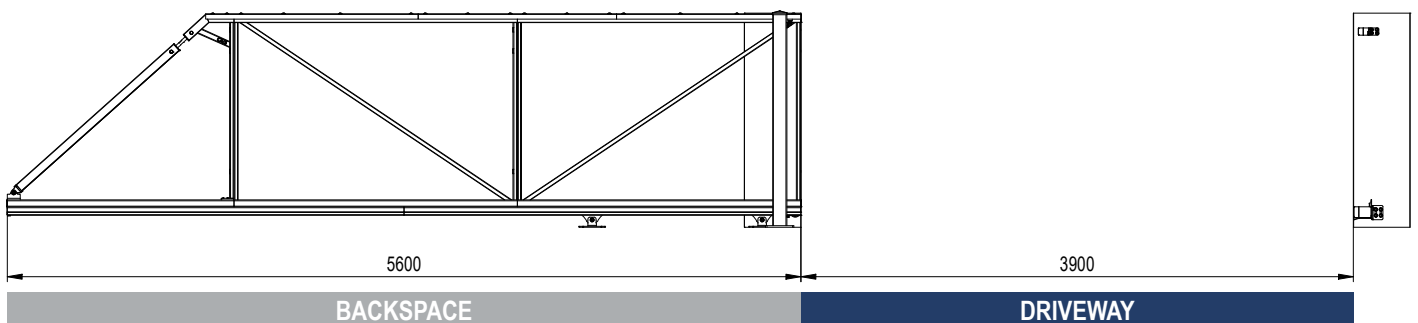
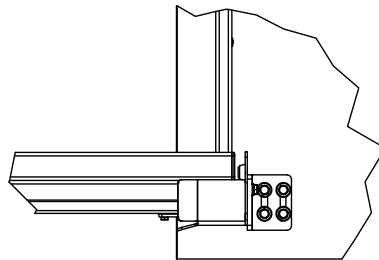

CONNECT 60

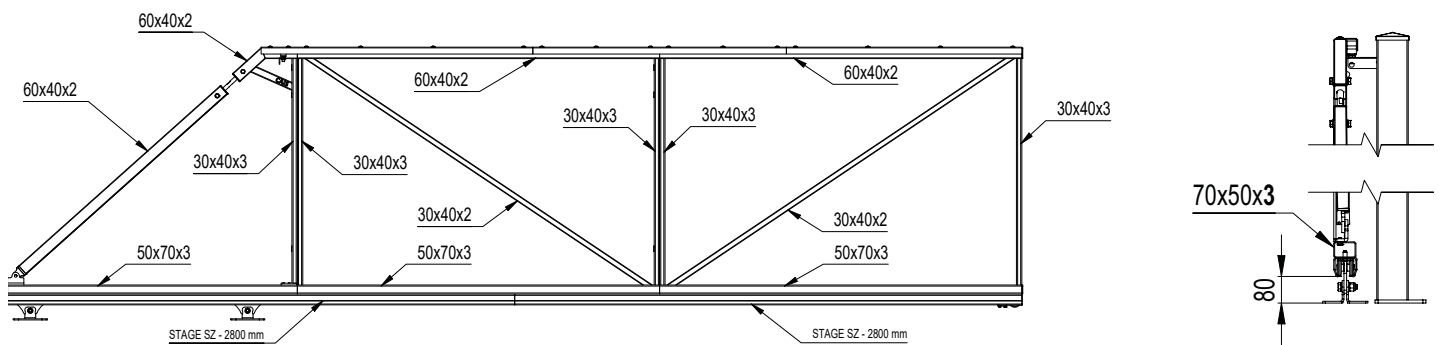
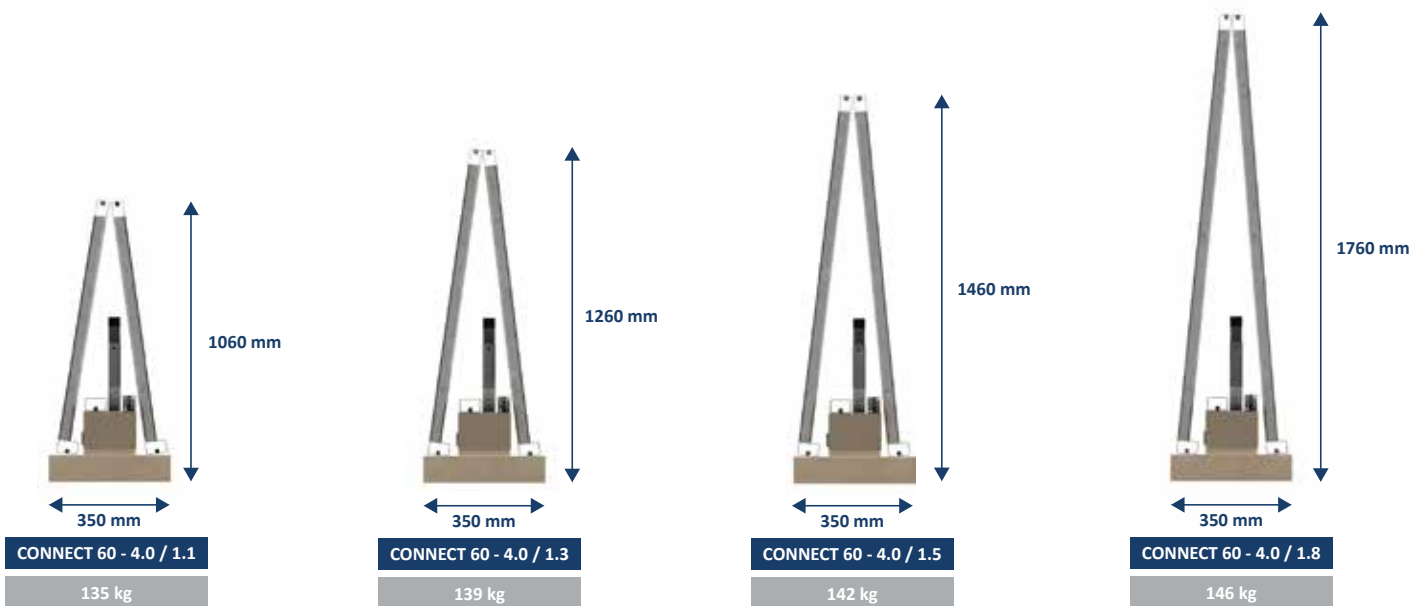

MAXIMUM LOAD ON THE GATE LEAF 125 kg

CERTIFICATION



CONNECT 60

REPORT OF ASSESSMENT OF PERFORMANCE
NO.755200134 / 2022

Notified Body No. 1023

**INSTITUTE FOR TESTING
AND
CERTIFICATION**

Třída Tomáše Bati 299
763 02 Zlín, Czech Republic
Division CSI - Centre of Civil Engineering



Assessed by
Ing. Vratislav Glos

26.05.2022

MANAGING DIRECTOR
Mr. Miroslav Cais



CAIS s. r. o.
Přehradní 199
763 16 Fryšták
Czech Republic



CONNECT 60
CANTILEVER GATE

22

EN 13241:2003+A2:2016

Serial number: 600000

Date:

Resistance

to wind load: Class

2006/42/ES

PATENT

OFFICE PŘIKRYL

has registered at industrial
property office for **GERMANY**
the utility model number
20 2015 103 846
for **E-BOX** cantilever gate,
produced by **CAIS s.r.o.**

ASSEMBLY MANUAL

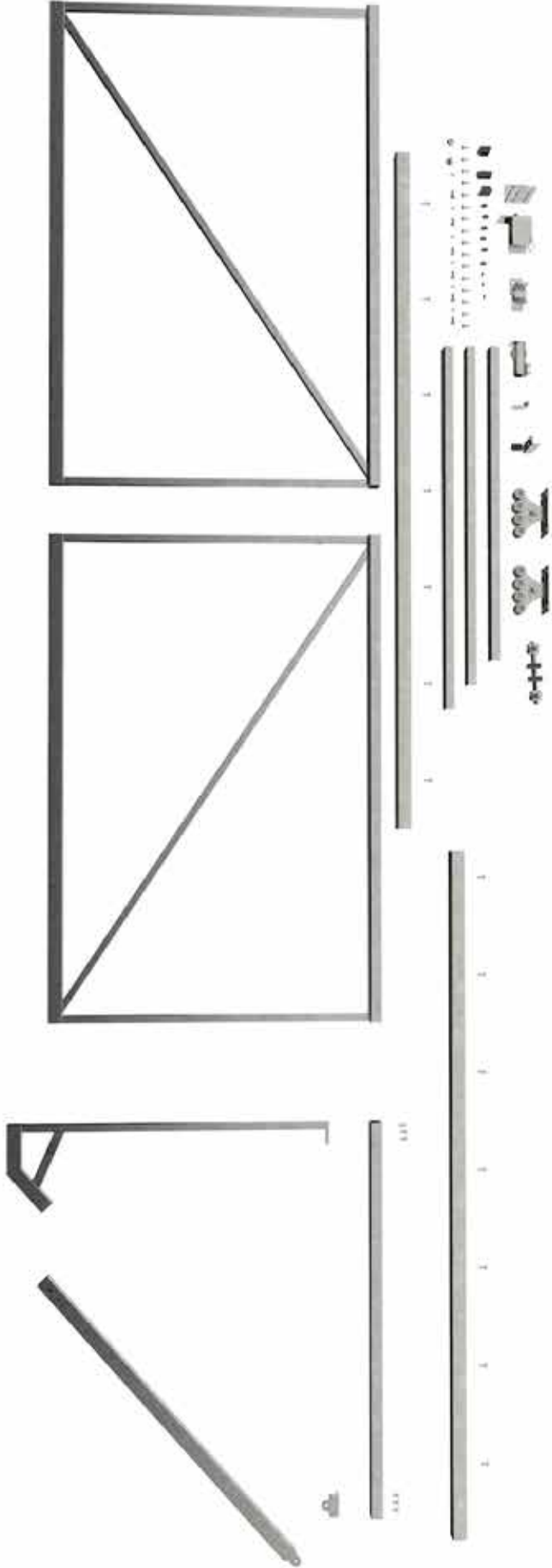
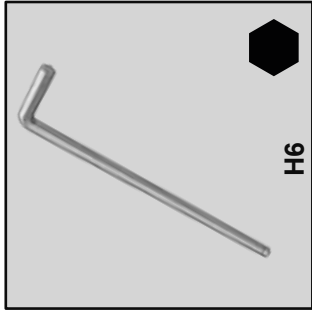
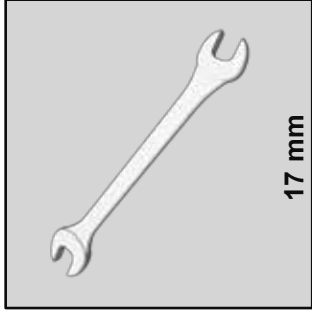
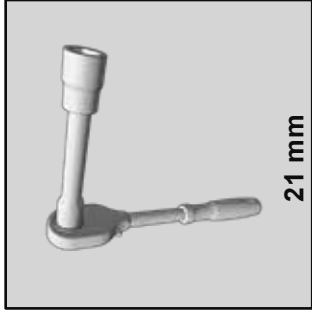
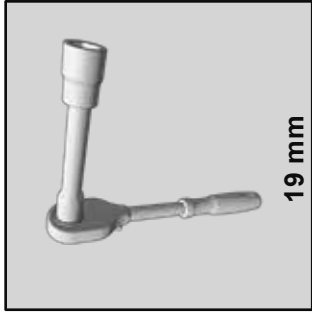
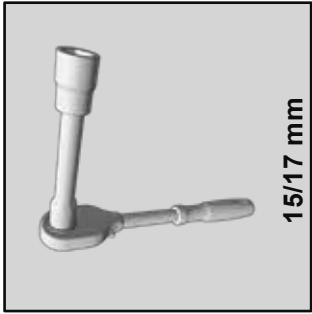

ASSEMBLY MANUAL

1

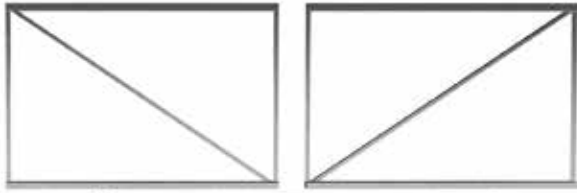

2

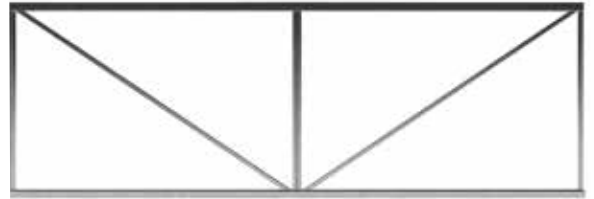

3



4



5





A - LEFT OPENING



6 A

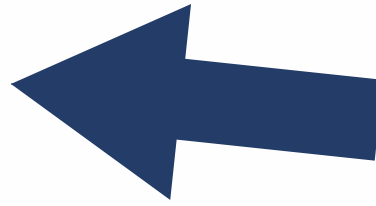

7 A

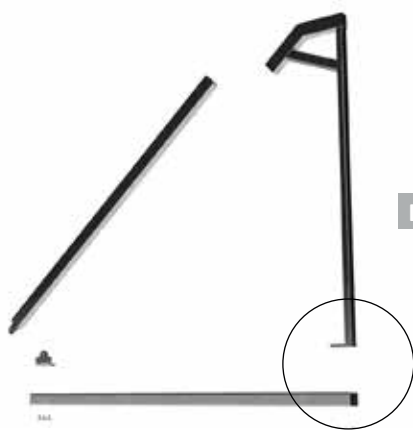

Detail: A1

8 A



15/17 mm

3 pcs M10x16

9 A



10 A



15/17 mm

3 pcs M10x16

11 A

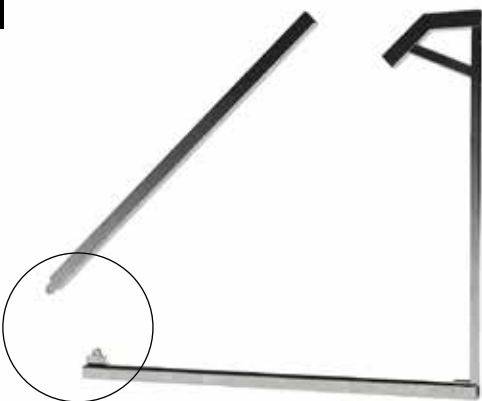

12 A



21 mm



21 mm

1 pc M14x45



B - RIGHT OPENING



6 B

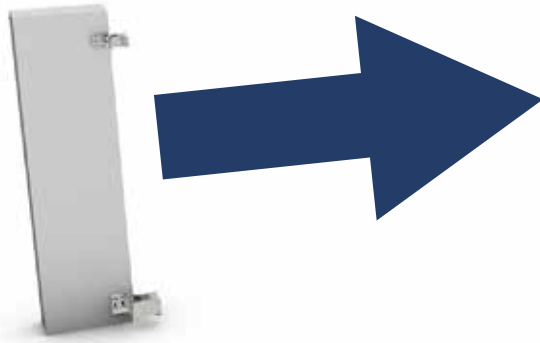

7 B

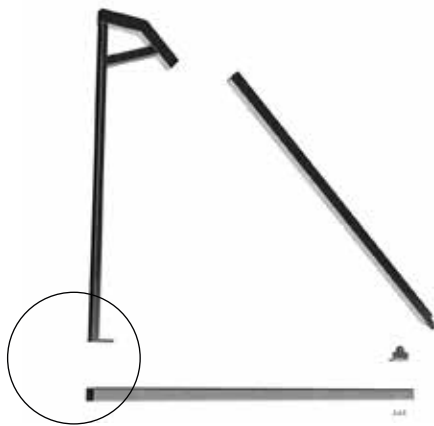

8 B



9 B



10 B



11 B

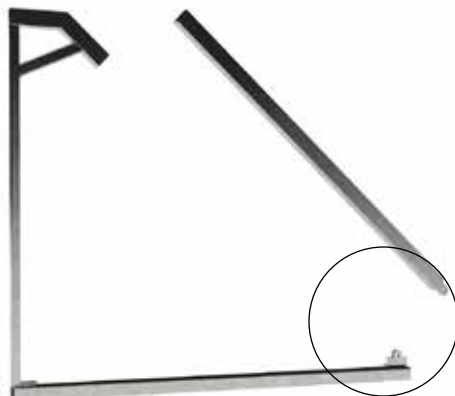

12 B

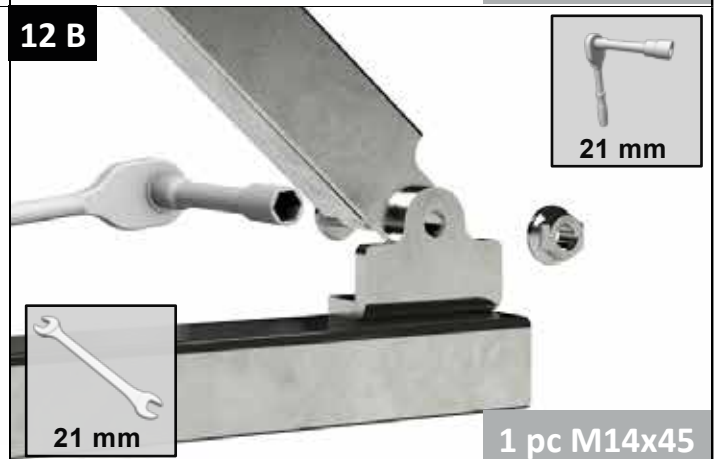

13

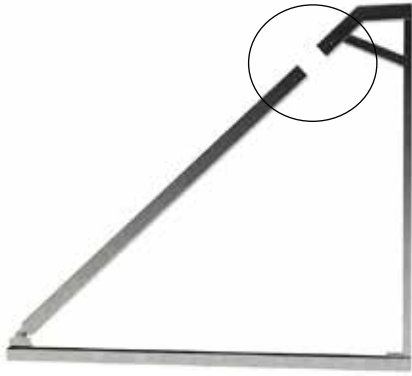

14

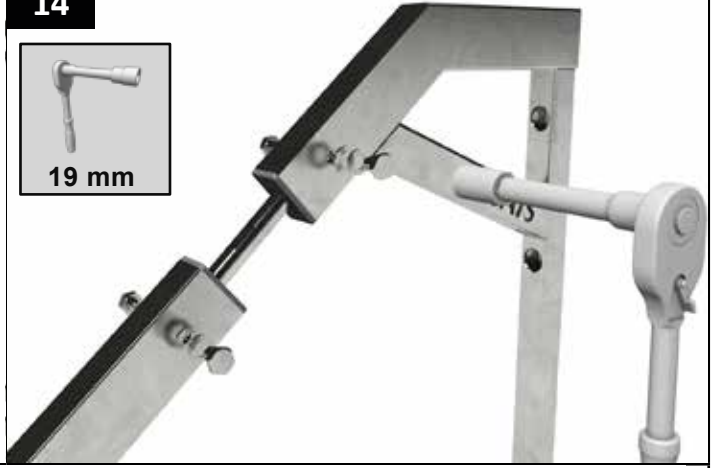
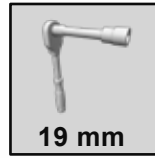

15



16



17



18





A - LEFT OPENING



19 A

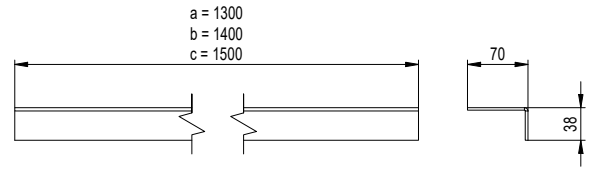
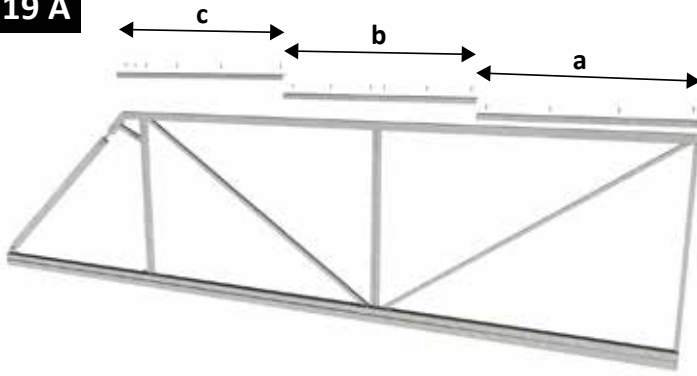

20 A

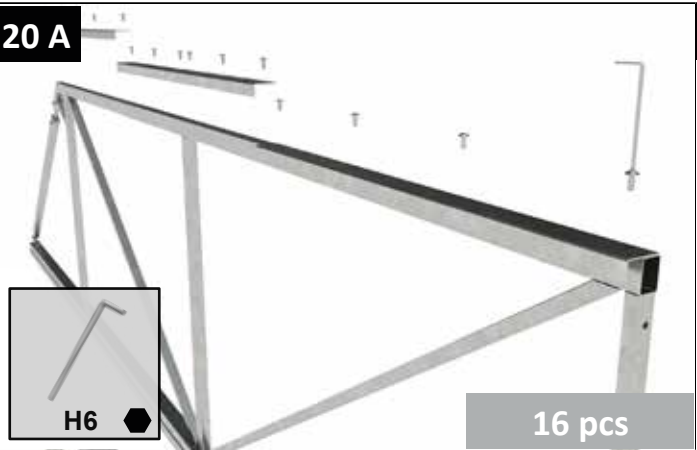

21 A

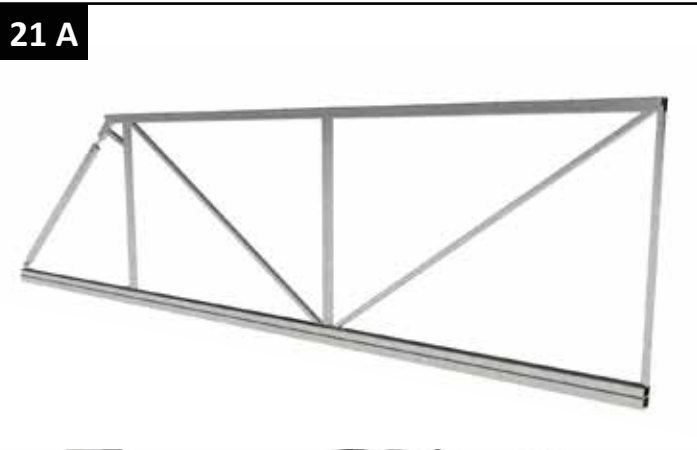

B - RIGHT OPENING



19 B

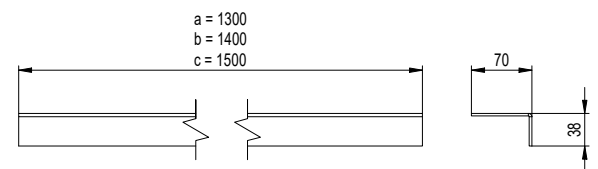
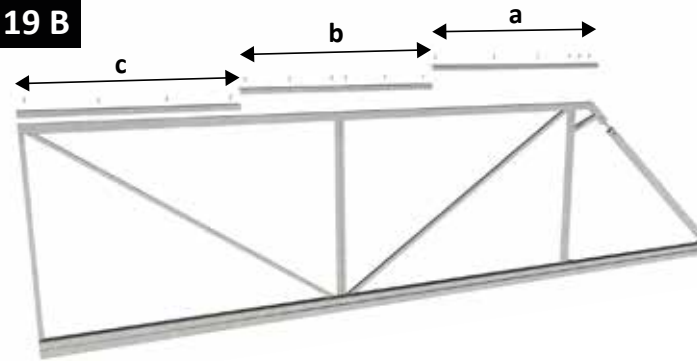

20 B

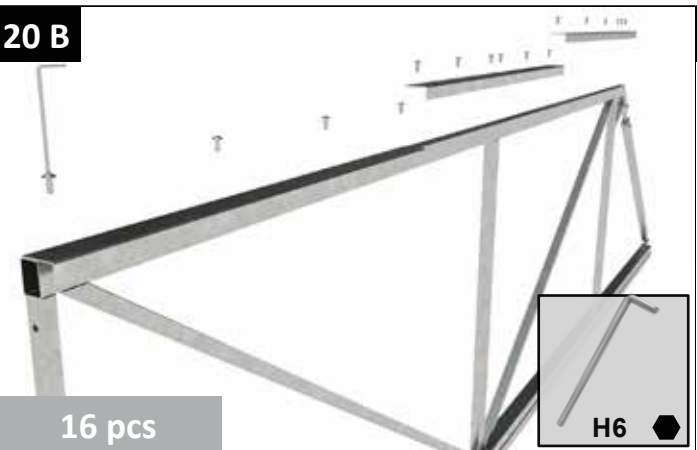

21 B

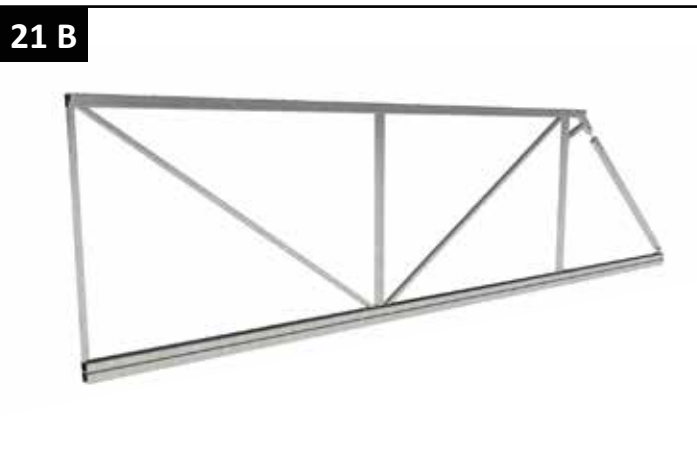

22

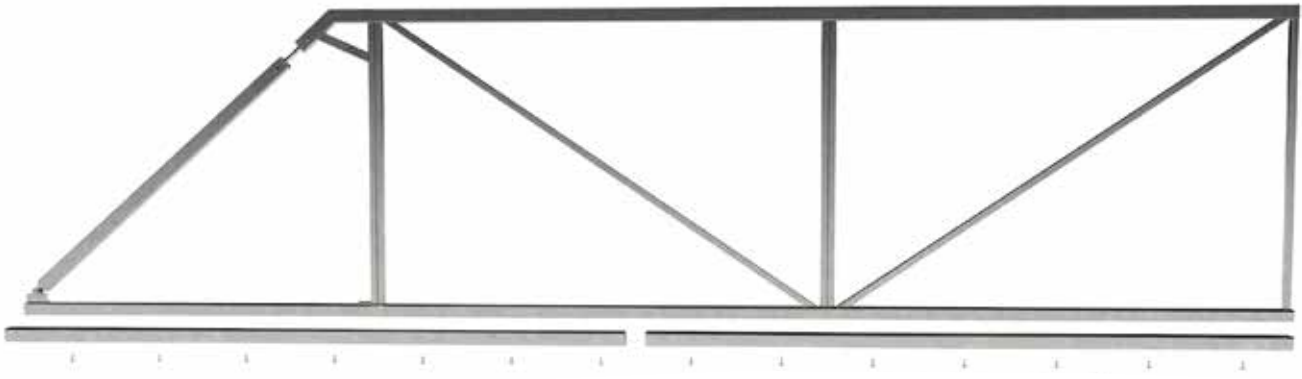

23



14 pcs

24

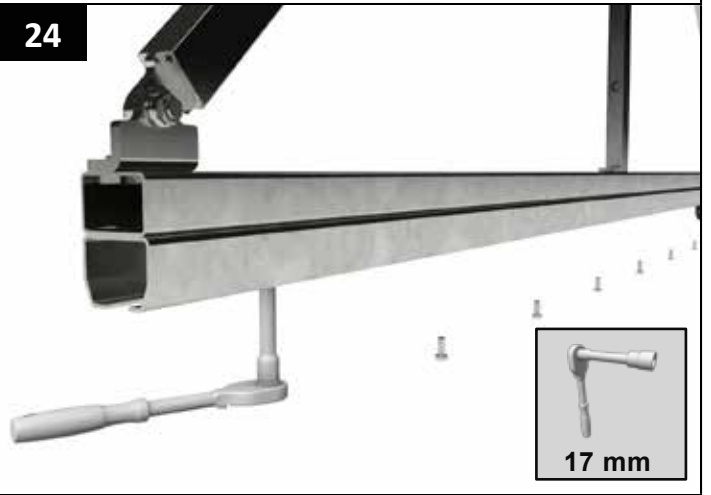

17 mm

25



CONSTRUCTION SITE PREPARATION

1



VIDEO
MANUAL



2

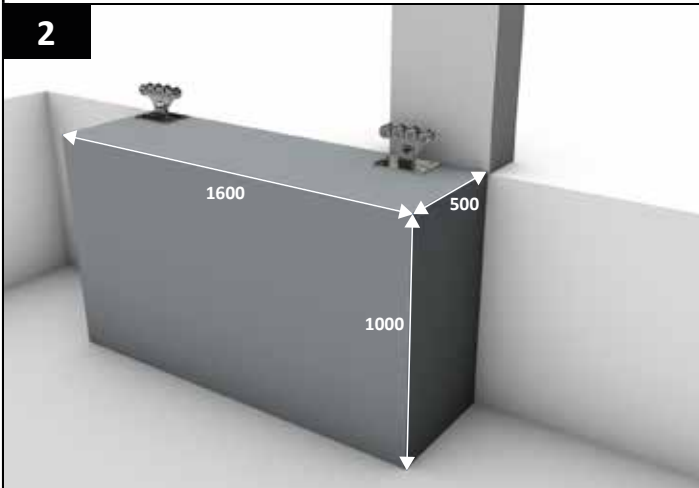

3

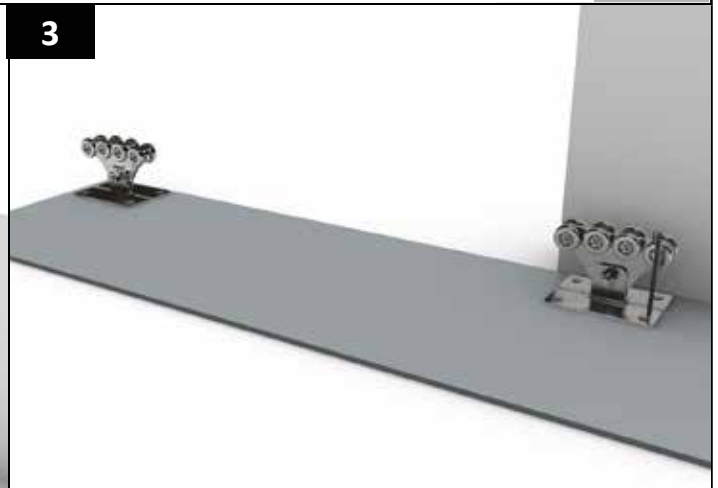

4

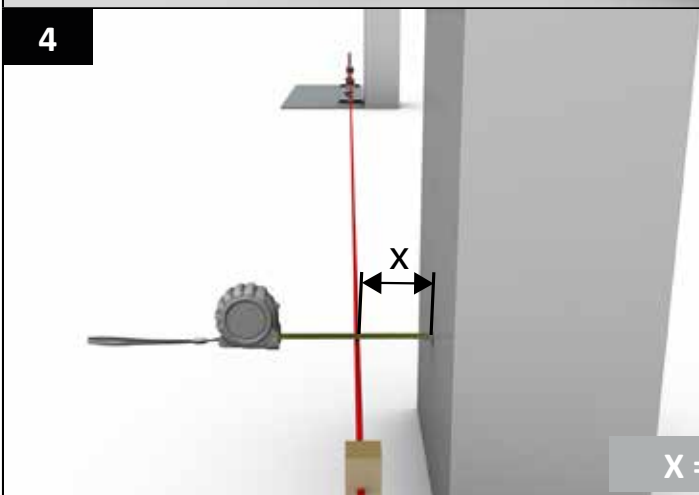

5

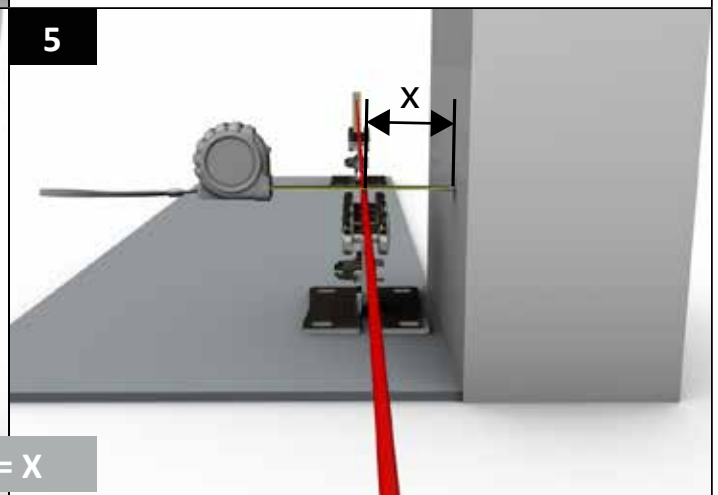

$X = X$

6

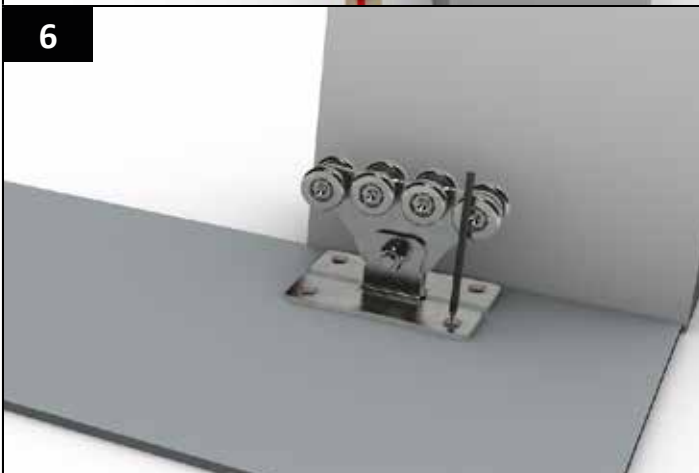

7

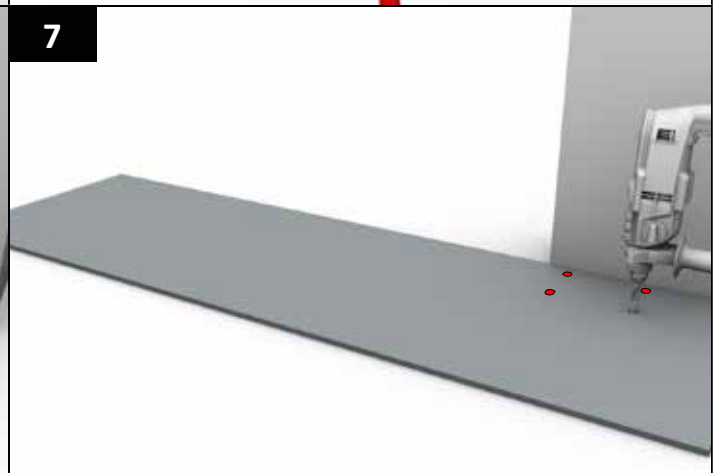

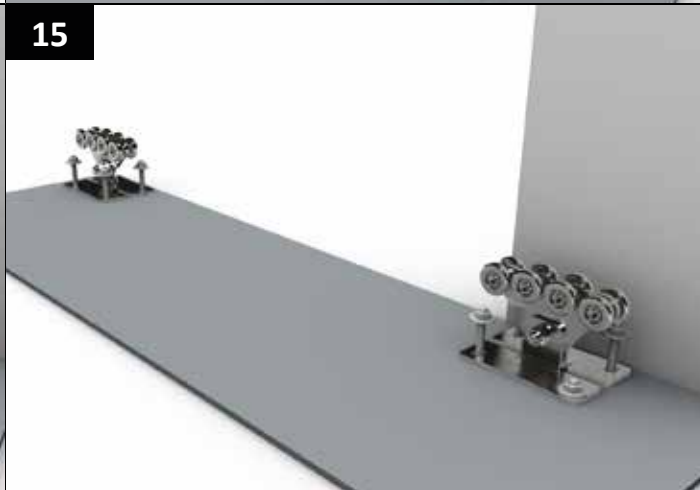
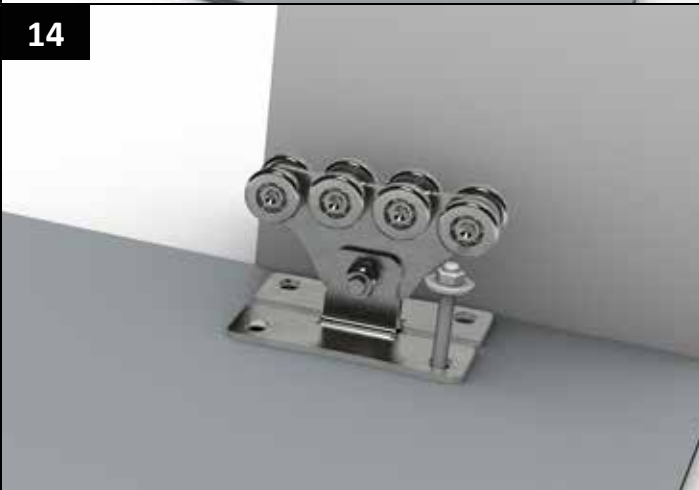
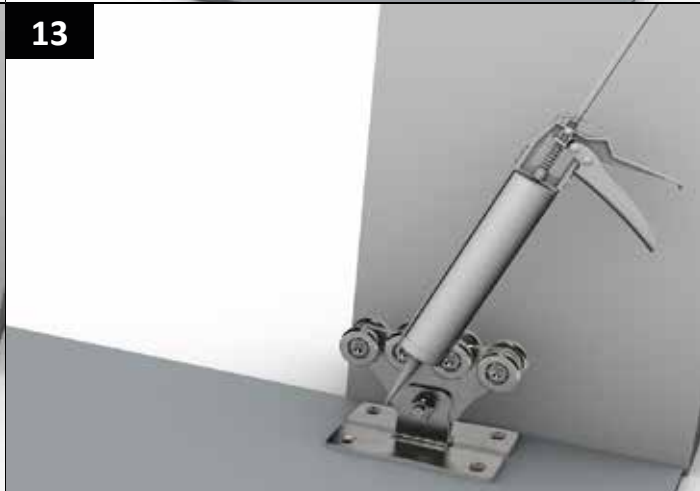
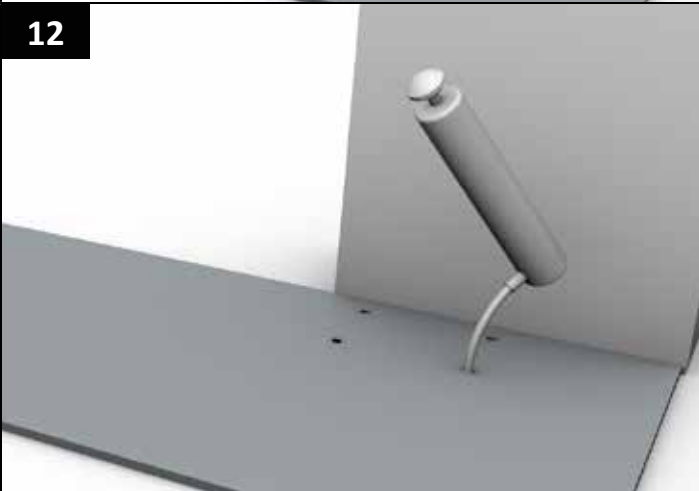
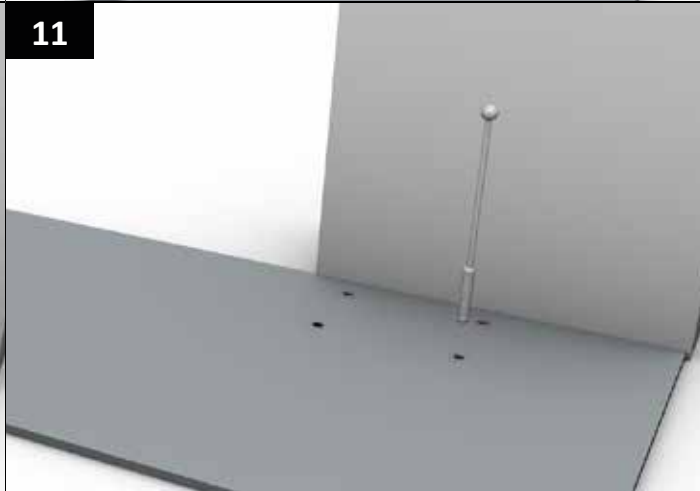
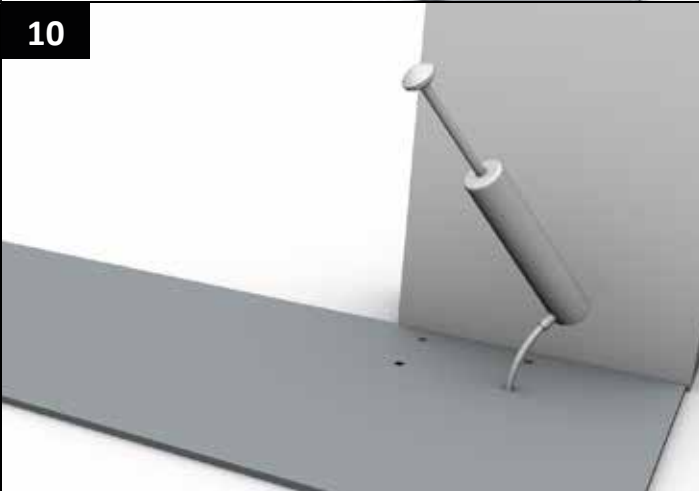
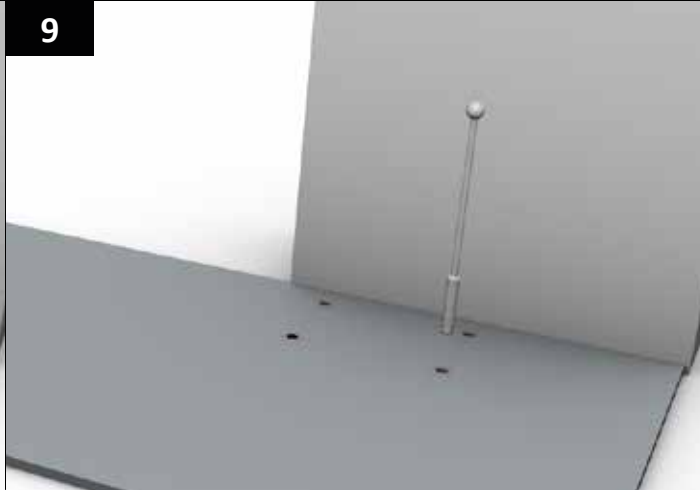
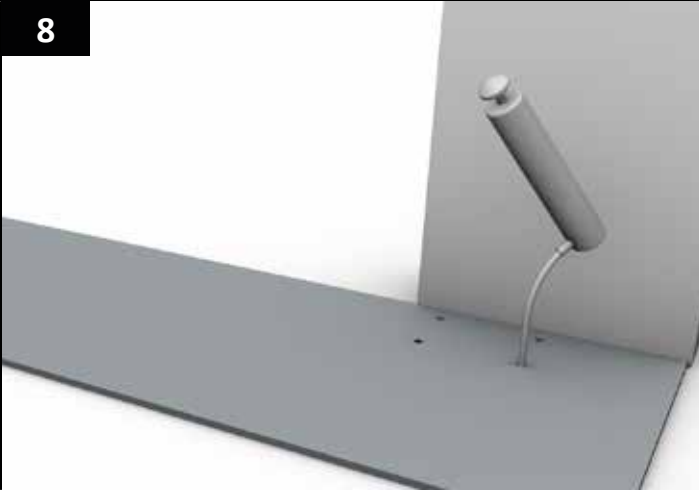

16

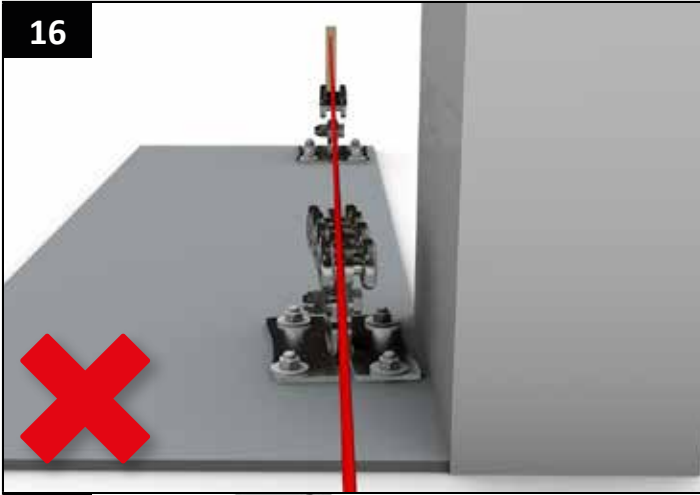

17

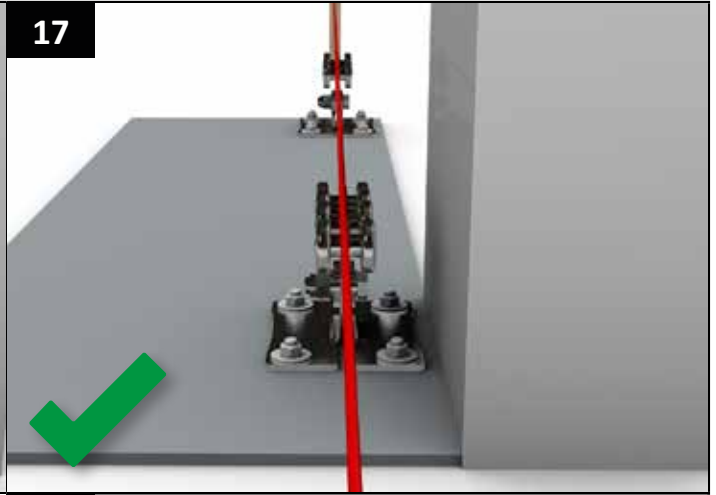

18

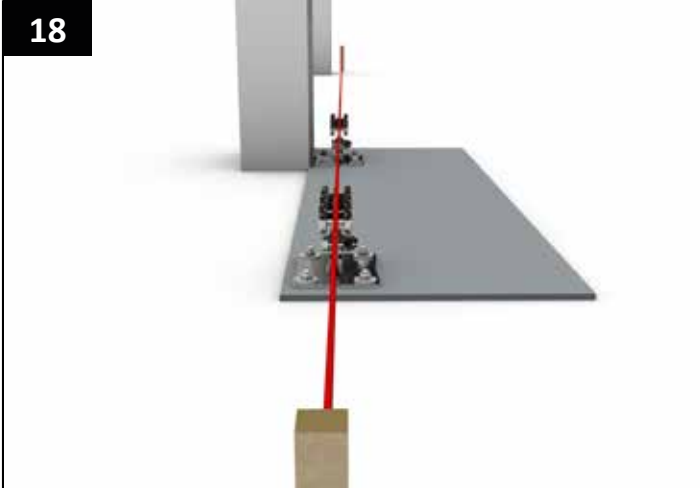

19



INSTALLATION MANUAL

1



2

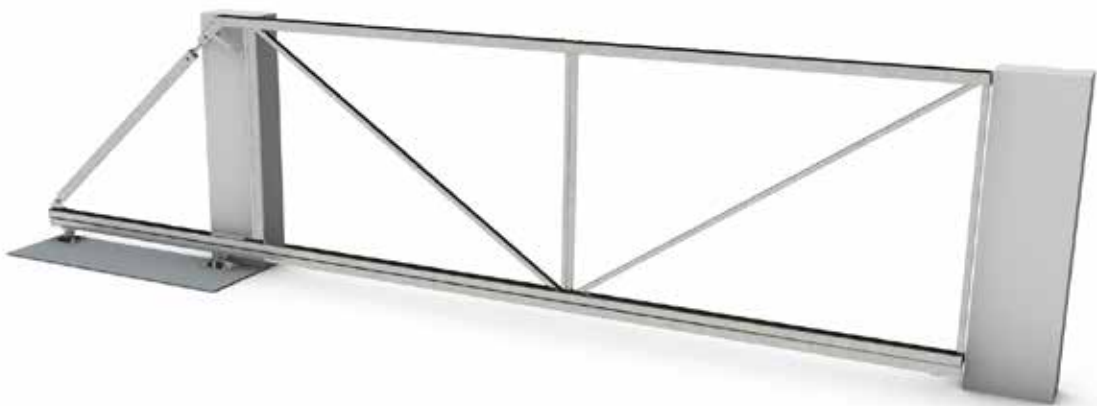

3

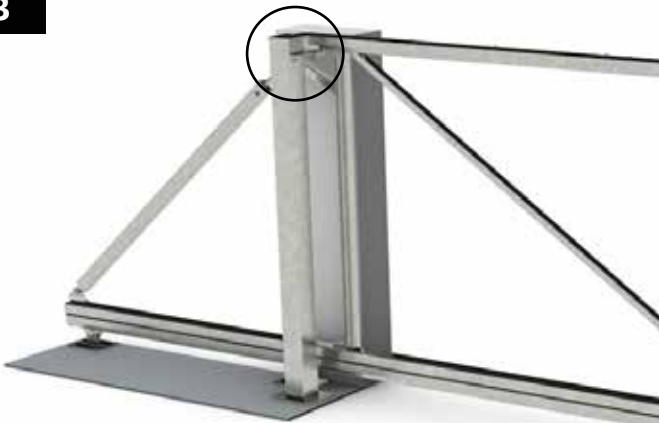

4

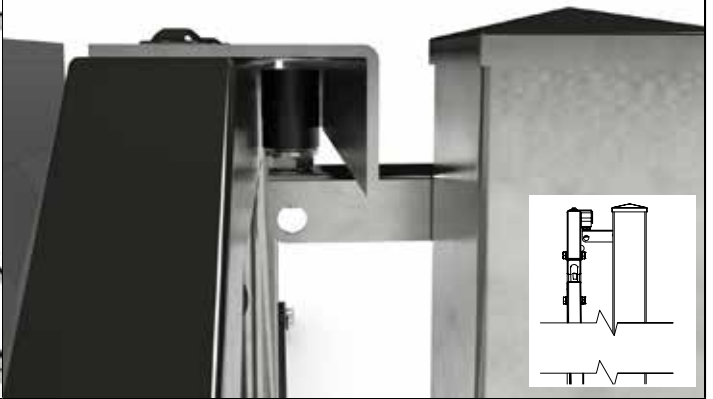

5



6



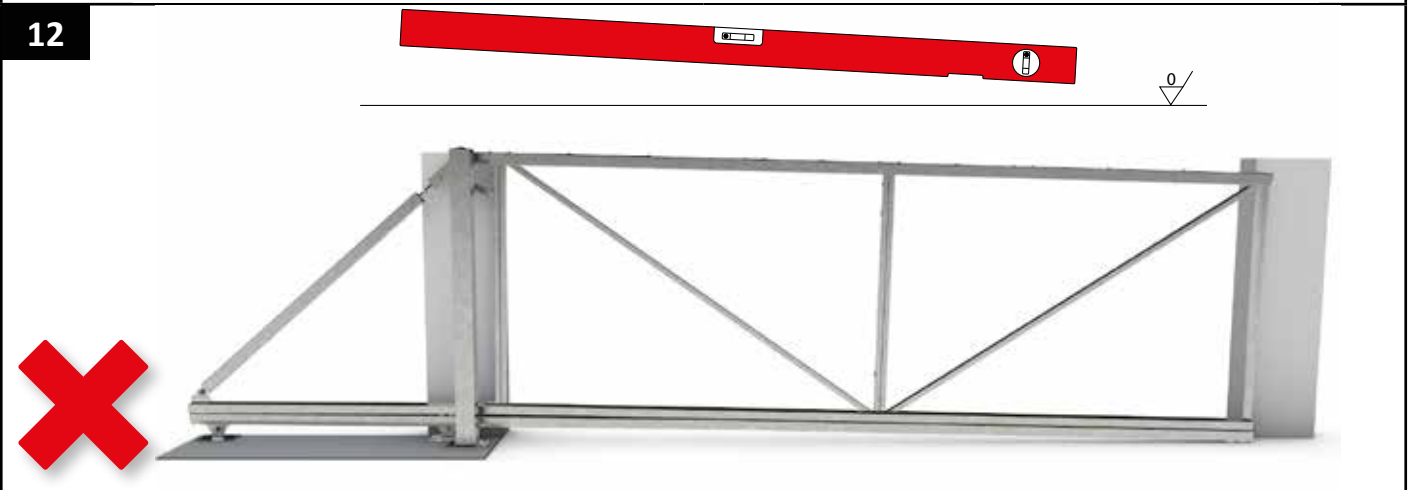
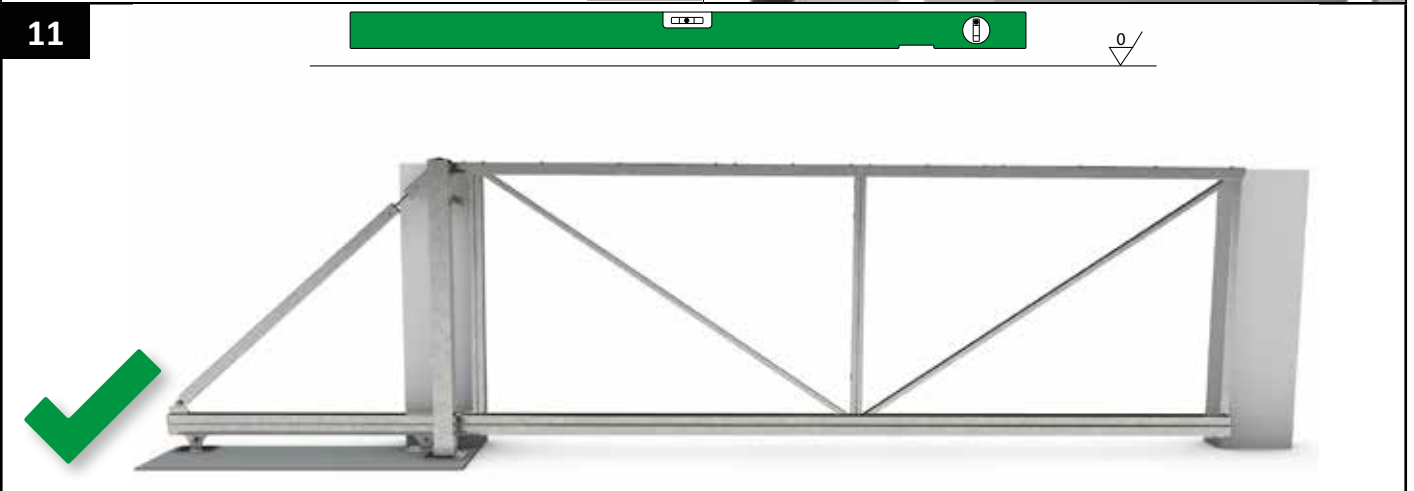
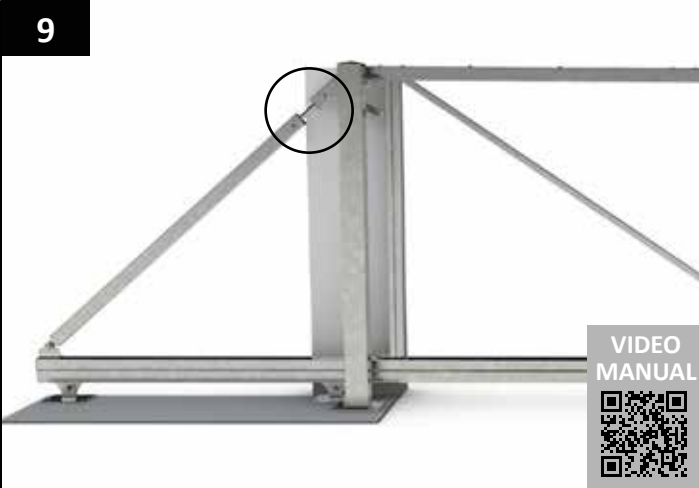

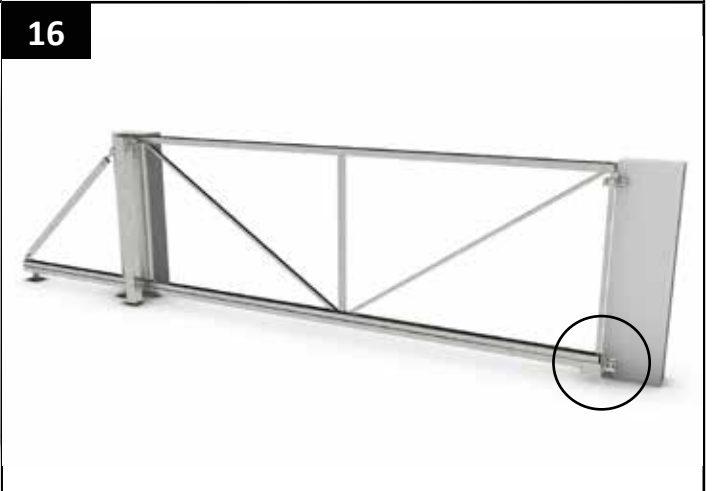
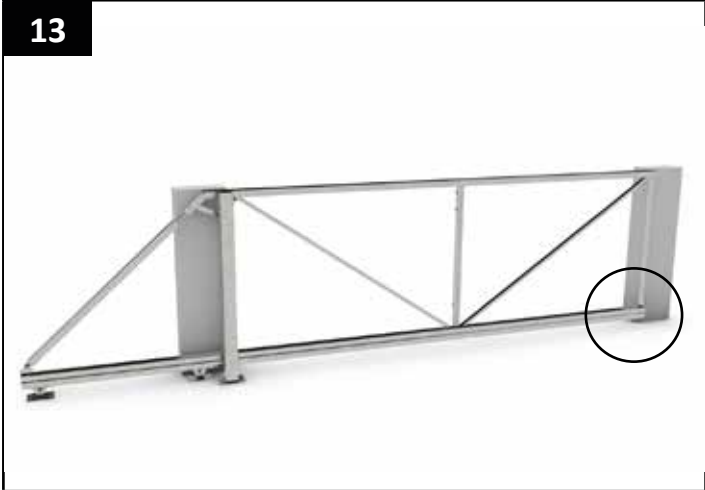

21

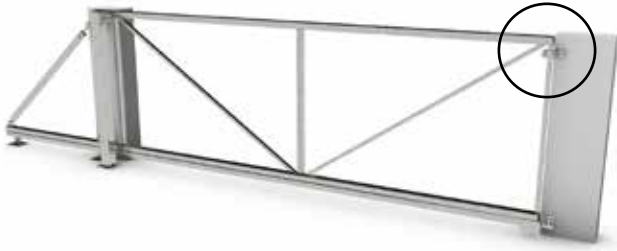

22



23



24



25

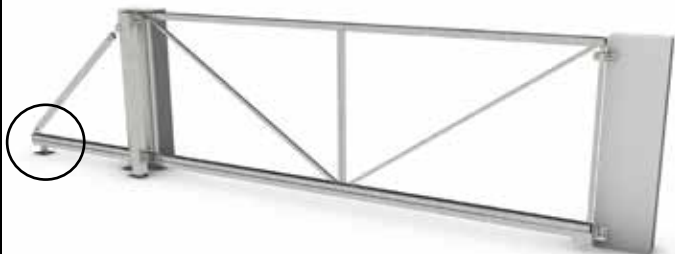

26



27



28

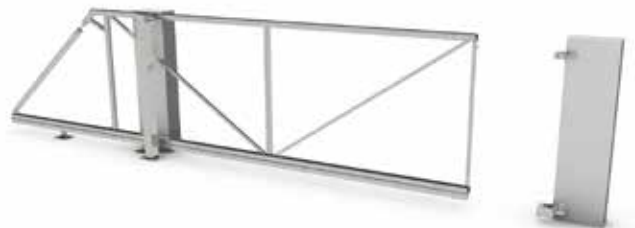

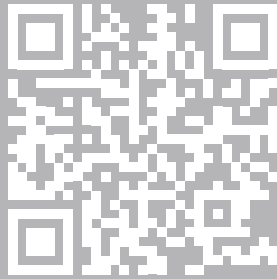

WWW.CAIS.EU